

# Hynautic trim tabs

## Hynautic

*The effort required to keep large pleasure yachts and commercial boats trim and level is usually too great for most fiberglass nylon trim cylinders, even when used in multiple combinations. This is especially true when backing down hard.*

*Based on an understanding of these forces, Hynautic offers a heavy duty brass trim cylinder powerful enough to move and maintain the position of even the largest trim planes.*

*And, this patented product is more durable because it resists corrosion by eliminating all external hoses, isolating dissimilar metals, and protecting vital seals.*

*Coupled with a Hynautic 12 volt or 24 volt pump the cylinder will extend quickly enough to make an immediate difference in the trim of your yacht or work boat.*



*(For most boats to 65 feet in length)*

TO ORDER, REQUEST  
PRODUCT INFORMATION OR  
RECEIVE TECHNICAL SUPPORT,  
CONTACT: [www.teleflexmarine.com](http://www.teleflexmarine.com)  
or call 604-270-6899

**NOTE:** When properly installed, these electro-hydraulic trim tab systems will allow adjustment of vessel's attitude (bow up/bow down and port/starboard list) while underway. Since many variables can affect trim tab performance and boat handling, please review the requirements for your application with Teleflex Canada. Vessels should be carefully water tested after installation to confirm proper operation of the system.

## Applications:

The Hynautic cruiser trim system is designed for yachts and commercial vessels. One brass trim cylinder provides a force equal to approximately 2.5 times that of the typical nylon cylinders.

Therefore, a Hynautic TCS-1-02 trim system, which includes separate port and starboard cylinder/pump assemblies is effective for most yachts to 65 feet using properly reinforced stainless planes. When more hydraulic muscle is needed, two cylinders per tab may be pressurized from a single pump as in the TCS-2-01 system.

Similarly, Hynautic can supply a system as complex as four cylinders moving a single trim plane from a single power pump source.

Because of the diversity of tab shapes and materials, the design is left to the builder and not included in the basic system.

## Features:

- **Double acting brass cylinder with a patented porting design:**  
All plumbing is left inside the transom. No external plumbing fittings to be damaged or corroded. The patented, double wall cylinders are pressurized in each direction which means they work equally as well at either holding the plane down against a force from below or preventing it from being pushed down from a force from above.
- **Simple, effective marine power pumps:**  
Available in 12 or 24 volt, these pump assemblies are easy to install and purge. The use of marine rated relays and switches adds to the product's durability.
- **A design mechanics can appreciate:**  
The cylinder is designed to be disassembled from outside the boat without removing the complete assembly from the transom. Where dissimilar metals might come in contact, they are separated by a neutral material to reduce the effects of electrolytic corrosion.
- **Uses Dexron III® type Automatic Transmission Fluid or equivalent.**

## Ordering Guide:

### TCS-1-01 2-CYLINDER SYS, 24 VOLT:

Control switch	1 ea .....	TC-03
Tab cyl. - cruiser	2 ea .....	TK-01
Power pump	2 ea .....	TP-01
Manual	1 ea .....	182037
Hose - 2 ft.	4 ea .....	207402

### TCS-1-02 2-CYLINDER SYS, 12 VOLT:

Control switch	1 ea .....	TC-03
Tab cyl. - cruiser	2 ea .....	TK-01
Power pump	2 ea .....	TP-02
Manual	1 ea .....	182038
Hose - 2 ft.	4 ea .....	207402

### TCS-2-02 4-CYLINDER SYS, 12 VOLT:

Control switch	1 ea .....	TC-03
Tab cyl. - cruiser	4 ea .....	TK-01
Junct. blk. ftg.	2 ea .....	TKF-02
Power pump	2 ea .....	TP-02
Manual	1 ea .....	182038
Hose - 2 ft.	12 ea .....	207402

### OPTIONAL PUMP:

Pump 24VDC.....	TP-03
-----------------	-------

## HYNAUTIC® TRIM TAB SYSTEM

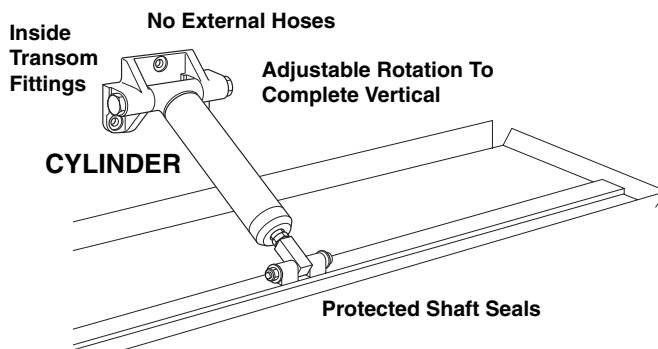
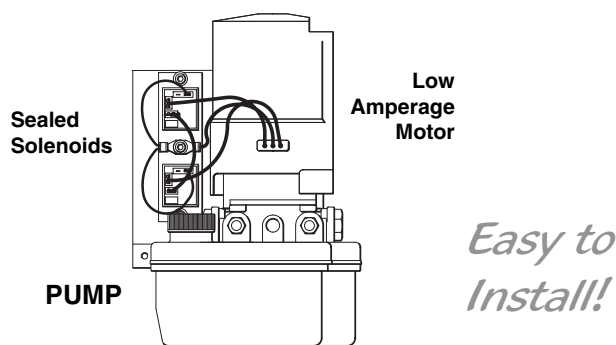

### SPECIFICATIONS

#### Trim Cylinder Assembly:

Model TK-01

STROKE = 4"

DISPLACEMENT = 5.94 in.(3)

FORCE = 2,230 LB. @ rated pressure

CONSTRUCTION = Brass/Bronze

DIMENSIONS:

Base = 7.13" X 3.75"

Cylinder = 14.0" Retracted

#### Pump Assembly:

Model	TP-02	TP-01	TP-03
DISPL (in.3/min.)	57	80	110
MOTOR	12VDC	24VDC	24VDC

### SYSTEM PERFORMANCE (Full Extension Time)

No. Cylinders per plane	(System Number in parenthesis)		
	Pump Models		
	TP-02	TP-01	TP-03
1	6.28 sec. (TCS-1-02)	4.46 sec. (TCS-1-01)	-
2	12.96 sec. (TCS-2-02)	8.91 sec. (TCS-2-01)*	6.48 sec. (TCS-3-03)*
3	19.44 sec. (TCS-3-02)*	13.38 sec. (TCS-3-01)*	9.72 sec. (TCS-3-03)*
4	-	17.82 sec. (TCS-4-01)*	12.96 sec. (TCS-4-03)*

Order the system number in parenthesis. \*Contact Teleflex Canada for information.