

# Teleflex Marine Mechanical Steering

## About Our Mechanical Steering Systems:

The following is a quick overview of our steering systems and steering component terminology. For details on a particular steering system (features, applications, ordering information and dimensions) noted below, refer to the catalog pages describing that steering system. Distinctions made below are generalizations and should be used in conjunction with the specific steering system sections of this catalog when selecting a system, and water testing the boat.

Mechanical cable steering is durable and reliable. Cable systems can to some degree be tailored to individual driving preferences. Turning the steering wheel turns a geared helm, which in turn moves a push-pull cable to turn the engine or rudder. Rotary (cable wraps around a gear) and Rack & Pinion (cable attached to rack gear moved by a pinion) versions are offered.

Various helms are available, each resulting in a different number of lock-to-lock steering wheel turns (specific to each steering system type, determined by helm gearing.) More wheel turns equals less effort to turn the wheel.

Features unique to their respective products include QUICK CONNECT® (SAFE-T® systems), Dual Station capability (BIG-T®), Rack & Pinion feel ("The Rack" systems), low-backlash (HPS™) and NO FEEDBACK™ (NFB™ systems.)

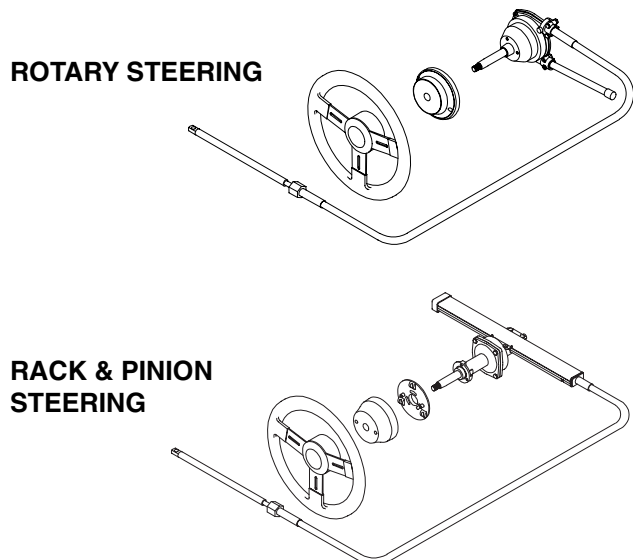

All our mechanical systems exceed A.B.Y.C. safety standards and ISO/I.M.C.I./N.M.M.A. certification requirements and feature stainless steel cable output ends.

### Typical Mechanical Steering System Components:

**HELM:** A dashboard-mounted gearbox to which the steering wheel and cable are connected. Turning the wheel turns gears in the helm and moves the mechanical steering cable, which in turn moves the engine through its steering arc, by means of a steering connection kit.

**BEZEL:** A dashboard trim piece that covers helm mounting hardware, takes up the space between steering wheel hub and dash, and provides additional steering shaft support. The bezel kit is specific to the type of helm.

**STEERING CABLE:** A mechanical push-pull cable assembly connected at one end to the helm and the other end to the engine or rudder. The cable transfers motion from the helm to linear motion at the engine tiller arm or rudder.

**CONNECTION KIT:** Hardware that connects:

1. the steering cable to the engine or tiller arm, and/or
2. the steering cable to the splashwell or other mounting point, and/or
3. connects one engine or rudder to the other in multiple engine/rudder applications.

