

NFB™ 4.2 outboard steering

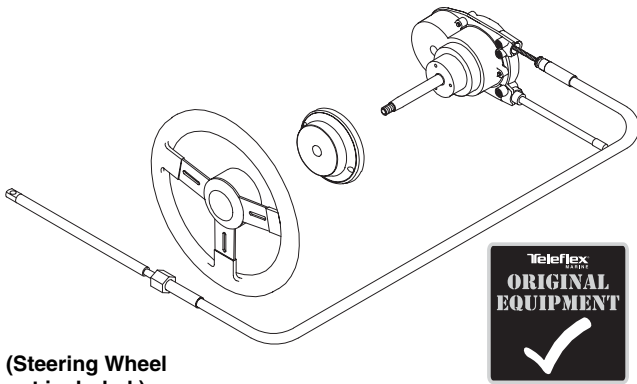

NFB™ 4.2 SINGLE CABLE SYSTEM



(Steering Wheel
not included.)



(4.2 turns lock-to-lock)

**NEW VERSIONS OF TILT
COMING SOON!
(Contact Teleflex Marine
for Details.)**

NOTE: When properly installed, this steering system will connect to engines with ABYC standard tilt tubes, using engine manufacturer's link arm. For other engines, see Steering Connection Kits section for options. **NFB is not for use with power-assisted steering or autopilots.**

Patented No FeedBack Steering Control for about the cost of an old-fashioned steering replacement. With the advantage of 4.2 turns lock-to-lock and our patented No FeedBack steering to lock out steering loads, Teleflex's 4.2 Rotary NFB Steering is the ideal single-cable system for most non-power-steered boats. The helm is a drop-in replacement for current generation Safe-T with no dash modifications required.

(See following pages for twin cable system.)

Applications:

NFB 4.2 single-cable systems are suitable for most single-station boats with a single non-power-assisted outboard engine up to V-6 and minimal engine flutter or steering instability. 4.2 accepts wheels up to 16" diameter.

Use dual cable system for boats with engine flutter or steering instability. (See page 38.)

Replaces nearly all Teleflex Safe-T® steering systems without dash modification.



Features:

- Patented No FeedBack™ Steering mechanism.
- Comfortable 4.2 turns from lock-to-lock.
- Minimal clutch free play.
- Standard 3/4" round tapered steering shaft.
- Stainless steel cable output ends.
- Fast, easy installation: uses Teleflex Quick Connect (QC) steering cable and industry-standard Safe-T mounting hardware.
- Kits include: cable, helm, 90° bezel and hardware.
- Meets A.B.Y.C. standards.
- Meets N.M.M.A. certification requirements.

mechanical rotary steering, non-power-assisted boats

Complete Systems:

NFB 4.2 Steering Kit
(Single Cable)..... SS147XX

(Kits available with steering cable lengths from 10-20 feet. If either a longer or shorter cable is required, please order your system by components, which are listed below.)

**NFB 4.2
SINGLE
CABLE
STEERING
KIT**



Components:

NFB 4.2 Helm.....SH4910P

QC Cable.....SSC62XX
(XX = cable length in feet. A 14' SSC62 would be SSC6214.)

Rotary NFB Bezel (90°).....SB27150P

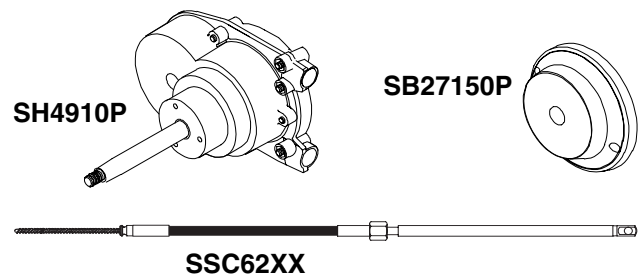

Options:

NFB 4.2 Single Tilt Dash Module..... SH1534910
Includes tilt helm and mechanism. Easy way to upgrade to Tilt or replace older Tilt systems. Requires SSC61 or SSC62 cable.

NFB 4.2 Single Tilt Helm SH91526P*
** Requires SH91500 tilt mechanism to complete Tilt Steering system installation.*

Performance Tilt MechanismSH91500P

Bezel (20°).....SB27483P

Cable Gard (fits most tilt tubes)SA39329P



**SH1534910
TILT DASH
MODULE**

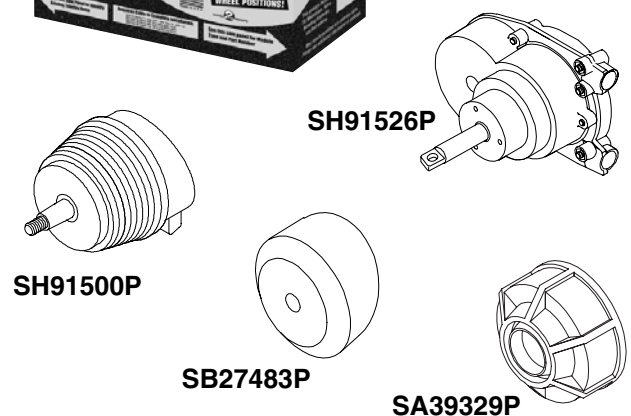

Service Items:

QC II Cable (for most Teleflex rotary)...SSC61XX

Steering Wheel Hardware Kit2745417P

Spent Travel Tube (Rotary NFB)SA38603P

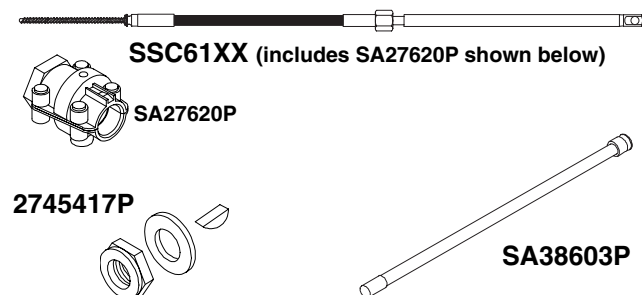

MECHANICAL STEERING NFB