

NFB™ 4.2 Tilt outboard steering

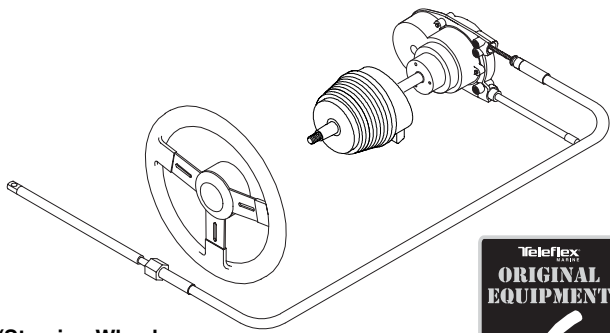

NFB™ 4.2 TILT SINGLE CABLE SYSTEM



(Steering Wheel
not included.)

(4.2 turns lock-to-lock)

**NEW VERSIONS OF TILT
COMING SOON!
(Contact Teleflex Marine
for Details.)**

NOTE: When properly installed, this steering system will connect to engines with ABYC standard tilt tubes, using engine manufacturer's link arm. For other engines, see Steering Connection Kits section for options. **NFB is not for use with power-assisted steering or autopilots.**

Patented No FeedBack Control — PLUS THE WORLD'S MOST POPULAR TILT STEERING! You get Tilt Steering, the advantage of 4.2 turns lock-to-lock and our patented No FeedBack steering to lock out steering loads! **Teleflex's 4.2 Rotary NFB Tilt Kit puts all the latest mechanical steering technology in one box!**

Applications:

NFB 4.2 Tilt single-cable systems are suitable for most single-station boats with a single non-power-assisted outboard engine up to V-6 and minimal engine flutter or steering instability. 4.2 Tilt accepts wheels up to 16" diameter.

Drop-in replacement for all current generation Teleflex Tilt Steering with *no* dash modification — and replaces other steering systems with *minimal* dash modifications.

Features:

- Teleflex Tilt Steering with 48° of total adjustment in five 12° increments.
- Patented No FeedBack™ Steering mechanism.
- Twin cable system for maximum control.
- Comfortable 4.2 turns from lock-to-lock.
- Minimal clutch free play.
- Standard 3/4" round tapered steering shaft.
- Stainless steel cable output ends.
- Fast, easy installation: uses Teleflex Quick Connect (QC) steering cable and industry-standard Safe-T mounting hardware.
- Meets A.B.Y.C. standards.
- Meets N.M.M.A. certification requirements.



mechanical TILT rotary steering, non-power-assisted boats

Complete Systems:

NFB 4.2 Tilt Steering Kit
(Single Cable)..... SS157XX

(Kits available with steering cable lengths from 11-25 feet. If either a longer or shorter cable is required, please order your system by components, which are listed below.)

**NFB 4.2
TILT
SINGLE
CABLE
STEERING
KIT**



Tilt
STEERING
available!

Components:

NFB 4.2 Single Tilt HelmSH91526P

Performance Tilt MechanismSH91500P

QC Cable.....SSC62XX
(XX = cable length in feet. A 14' SSC62 would be SSC6214.)

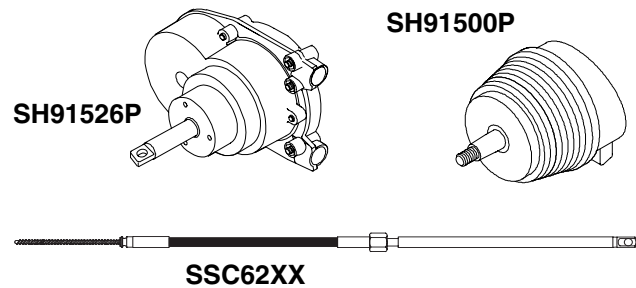

Options:

Cable Gard (fits most tilt tubes) SA39329P



Service Items:

NFB 4.2 Single Tilt Dash Module..... SH1534910
Includes tilt helm and mechanism. Easy way to upgrade to Tilt or replace older Tilt systems. Requires SSC61 or SSC62 cable.

NFB 4.2 Single Tilt Helm SH91526P*
** Requires SH91500 tilt mechanism to complete Tilt Steering system installation.*

Performance Tilt MechanismSH91500P

QC II Cable (for most Teleflex rotary)...SSC61XX

Steering Wheel Hardware Kit2745417P

Spent Travel Tube (Rotary NFB) SA38603P



**SH1534910
TILT DASH MODULE**

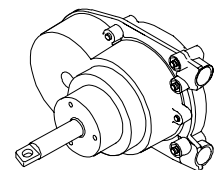

SH91526P

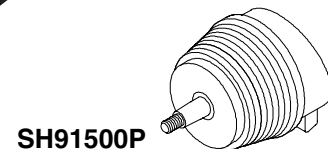

SH91500P



SSC61XX (includes SA27620P shown below)



SA27620P



2745417P

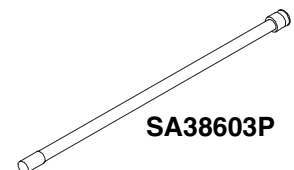

SA38603P

MECHANICAL STEERING NFB