

# NFB™ Safe-T® II outboard steering

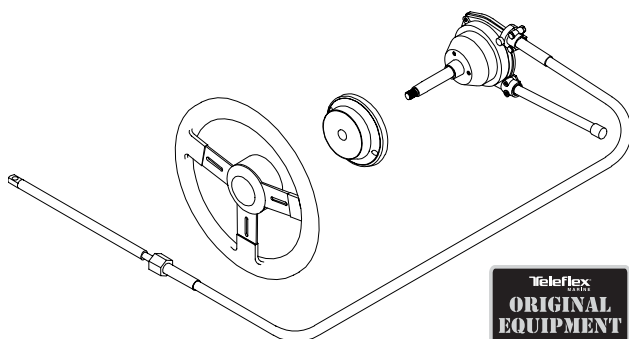

**Major OEMs use Teleflex Safe-T II, and so will your customers. It's the next generation of Safe-T, the world's #1 rotary steering system — rugged, compact, lightweight, and with Teleflex No FeedBack technology. This ultra-smooth 3-turn system takes the work out of steering most V-4 outboard powered boats. The Safe-T II helm is a drop-in replacement for current generation Safe-T QC with no dash modifications!**

## NFB™ SAFE-T II SINGLE CABLE SYSTEM



(Steering Wheel not included.)



## Applications:

NFB Safe-T II single-cable systems are suitable for most single-station boats with a single non-power-assisted outboard engine up to V-4 and minimal engine flutter or steering instability. Safe-T II accepts wheels up to 16" diameter.

(NFB Safe-T II is available in single cable configuration only).

Replaces nearly all standard Safe-T® steering without dash modifications.



*(3 turns lock-to-lock)*

**NEW VERSIONS OF TILT COMING SOON!  
(Contact Teleflex Marine for Details.)**

**NOTE:** When properly installed, this steering system will connect to engines with ABYC standard tilt tubes, using engine manufacturer's link arm. For other engines, see Steering Connection Kits section for options. **NFB is not for use with power-assisted steering or autopilots.**

## Features:

- Patented No FeedBack™ Steering mechanism.
- Quick response of 3 turns lock-to-lock.
- Minimal clutch free play.
- Standard 3/4" round tapered steering shaft.
- Stainless steel cable output ends.
- Fast, easy installation: uses Teleflex Quick Connect (QC) cable & standard Safe-T mounting hardware.
- Kits include: cable, helm, 90° bezel and hardware.
- Meets A.B.Y.C. standards.
- Meets N.M.M.A. certification requirements.

mechanical rotary steering, non-power-assisted boats to V-4

## Complete System:

NFB Safe-T II Steering Kit..... SS132XX

(Kits available with steering cable lengths from 10-20 feet. If either a longer or shorter cable is required, please order your system by components, which are listed below.)

## Components:

NFB Safe-T II Helm .....SH5150P

QC Cable.....SSC62XX  
(XX = cable length in feet. A 14' SSC62 would be SSC6214.)

Rotary NFB Bezel (90°).....SB27150P

## Options:

NFB Safe-T II Tilt Dash Module..... SH1535150  
**Includes** tilt helm and mechanism. Easy way to upgrade to Tilt or replace older Tilt systems. Requires SSC61 or SSC62 cable.

NFB Safe-T II Tilt Helm..... SH91190P\*  
\* Requires SH91500 tilt mechanism to complete Tilt Steering system installation.

Performance Tilt Mechanism.....SH91500P

Bezel (20°).....SB27483P

Cable Gard (fits most tilt tubes) .....SA39329P

## Service Items:

QC II Cable (for most Teleflex rotary)...SSC61XX

Steering Wheel Hardware Kit .....2745417P

Spent Travel Tube (Rotary NFB) .....SA38603P

Hitch Pin for Quick Connect Helms ....2724514P

NFB  
SAFE-T II  
SINGLE  
CABLE  
STEERING  
KIT

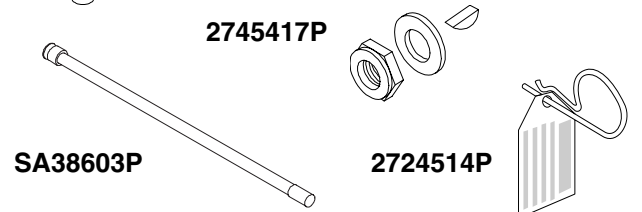
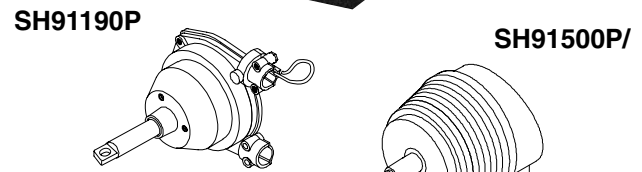
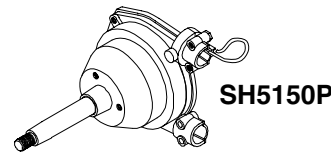

MECHANICAL STEERING NFB