

Teleflex Marine Premium Steering

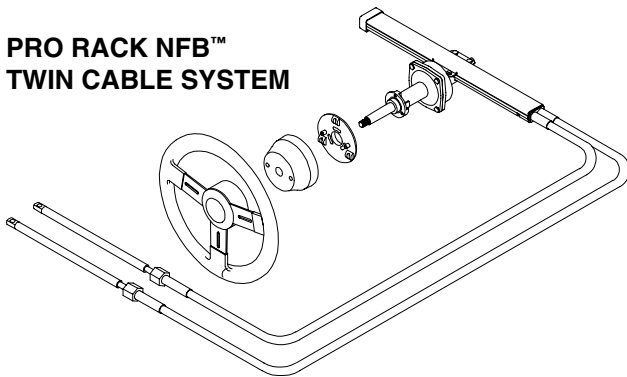

premium
outboard steering

**PRO RACK NFB™
TWIN CABLE SYSTEM**



NFB systems are NOT for use with power-assisted steering.

No FeedBack Steering for Outboards

Steering loads exist in all outboard-powered boats. These steering loads are actually turning energy from your engine's propeller.

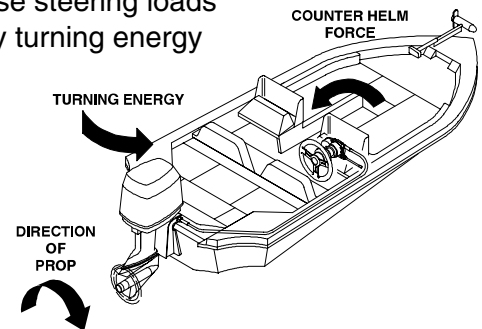

NFB™ steering locks out the prop feedback load which causes hard-to-handle steering, *without affecting horsepower*. With NFB the wheel doesn't turn until **you** turn it.

**PRO RACK
NFB™ HELM
CUTAWAY**

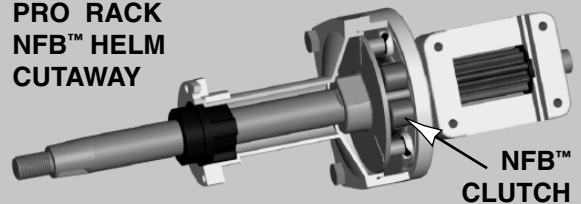

Featuring TFX™REME Technology

premium
stern drive steering

**HPS™ RACK
SINGLE CABLE SYSTEM**

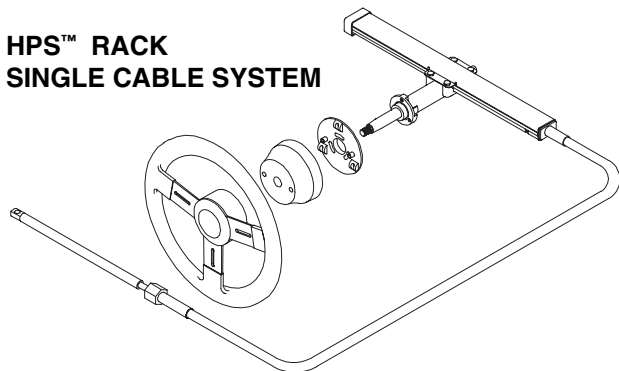

HPS systems are for use with power-assisted steering.

HPS for Stern Drives

Designed exclusively for boats with power-assisted steering, HPS steering reduces the backlash (free-play or "slop" felt at the wheel) often associated with power steered boats by up to 50%.

HPS systems are designed to handle the full steering load and can serve as the manual backup system in the event of power steering failure. Helms fit industry-standard Teleflex dash cutouts for Safe-T®, The Rack™ and Tilt™.

HPS cables use Teleflex TFX™REME® technology to deliver smooth feel and sure response with minimal lost motion.

**HPS™ RACK
CABLE
CUTAWAY**

