

Tech Reference: Controls

do
you
need
more
information?

The following section addresses technical questions often asked about mechanical controls. It is organized by frequency of question. If you require further assistance, please contact Teleflex Marine Tech Service as noted below.

*For Technical Support of
Teleflex Mechanical Products,
contact:*

TeleflexMarine
640 North Lewis Road
Limerick, PA 19468-5048
Phone: 610-495-7011
FAX: 610-495-7688
www.teleflexmarine.com

Tech Reference: Controls

Frequently Asked Questions

What kind of control cables go on my boat? The boat has a [brand name] engine.

There are several ways to determine this information by noting:

- a. appearance of the cable
- b. part number of the cable
- c. engine(s) and controls on which cable is used

Take a look at the existing cable.

Usually the part number is stamped in white on the existing cable's plastic outer casing.

If you can't locate it or read the part number, check to see what brand of control and brand/year of engine is on the boat now.

With this information, you can determine which cable you need from identification/application charts in this catalog. These charts will help you identify cables by appearance, part number, control type and engine brand/type.

In most cases, Teleflex offers three performance grades, called Standard, Midrange and Premium. All three grades meet/exceed industry requirements.

For maximum performance, we **recommend our Premium TFXTREME® cables.**

Once the part number of the replacement control cable(s) is(are) known, measure the one(s) you have now if at all possible.

Please see "How to Measure Control Cables" in this catalog and take special note of how measurements are made. ***The most frequent reason for the return of a new cable is that the incorrect length was ordered.***

If you are not sure what to do, please contact Teleflex Tech Support.

Can I use a dual function control in a dual station boat?

No. It is not recommended. Use of dual function controls for twin stations can result in a binding problem and is a complex, difficult installation in the best circumstances.

Instead, use one single function dual lever control per engine at each station. We have several from which to choose, but **recommend the CH5600P** — a state-of-the-art mechanical control specifically designed to work smoothly in twin station boats.

Single function controls for twin stations are set up with the cables "in series". This means that each cable is run from one lever of an upper station control to the corresponding lever of the lower station control. Another cable is then run from the lower station control to the engine. When the cables are properly connected, moving the levers at one station will move the levers at the other station in addition to actuating throttle and shift.

Shift detents should be used in the lower station control(s) (closest to the engine) only. Do not install shift detents in the second station control.

When mechanical controls are used in two stations, we always **recommend TFXTREME® cables**, which are also specifically designed to work smoothly in twin station applications. When combined with CH5600 controls, these cables give you superior smoothness and response. Because of their unique construction, these cables have very little backlash, so a high-quality synchronization of the control head lever position and feel at each station (including shift detents) is possible.

If a mechanical control system cannot deliver acceptable feel or response, upgrade to an electronic control system. Teleflex has several options, ranging from the relatively simple KE-4a system to the fully-featured i6000 family of controls.

If you are not sure what to do, please contact Teleflex Tech Support.

I want to add a station to my boat. What do I need to do?

First determine the type of steering and control systems on your boat now. That will help you identify the options available to you.

Measure the distance between stations and approximately how you would route the cables from one station to another.

This will give you a starting point as to which components you may need and how long any cables might be.

Generally speaking, if the run between stations is relatively short and uncomplicated, mechanical controls will do.

(Please see previous FAQ for information about which kind of control is recommended and general installation parameters).

If the run between stations is long or complex or there are more than two stations on the boat, mechanical controls are not recommended.

Use an electronic control system instead.

(Please see previous FAQ for options.)

For twin-station steering there is only one mechanical option: Big-T®. While this is an excellent system, it is old technology.

SeaStar® hydraulic steering is recommended, which offers superior steering and allows for connection of autopilots and numerous other system enhancements.

When adding a station, a substantial amount of components will be required no matter which types of systems are selected.

If the boat has mechanical steering and controls, this is a good time to consider upgrading to SeaStar hydraulic steering and the KE or i6000 family of electronic controls.

If you are not sure what to do, please contact Teleflex Tech Support.

I have a Teleflex/Morse control from 1989 and I need internal parts. Are any available?

We do not make available internal repair parts for any of our control or steering components.

Proper field repair of these components is not possible.

The only service parts offered are those listed in this catalog on the page with each control.

Generally speaking, these are cable attachment/hardware kits, neutral safety switches, handle knobs and other optional accessories.

For some control models, we do offer additional service parts.

If the repairs your control needs cannot be made, please replace it for safety reasons.

Teleflex offers the most comprehensive line of marine controls available — it is likely we have one that is a drop-in replacement (or very close to one).

An overview of our controls line and specifics on each model are shown earlier in this section.

If you are not sure what to do, please contact Teleflex Tech Support.

U.S./Metric Conversion Chart:

UNIT	X	= UNIT
U.S. TO METRIC:		
Feet	.3048	Meters
Meters	3.2808	Feet
Cubic Inches	16.38	Cubic Centimeters
METRIC TO U.S.:		
Inches	25.4	Millimeters
Millimeters	.0394	Feet
Cubic Centimeters	.06105	Cubic Inches

Tech Reference: Controls

Frequently Asked Questions

My control used to work fine, but now one lever is hard to move. What should I do to fix this?

First determine where the problem lies. There are three possible trouble areas: the control, the cable, and the throttle or transmission connection. By isolating these one at a time, you will find the problem. Engine(s) must be OFF when performing these checks:

- a. Disconnect the cable at the throttle or transmission attachment point. Move the throttle or transmission arm through its arc to be certain there is no restriction or binding. If the arm is stiff or binding, clean and lubricate moving parts. If this does not solve the problem, make the appropriate repairs. Generally, the force required to move a throttle or shift arm should be no more than 5-10 pounds.
- b. With the cable disconnected at the engine end, try to move the control lever. If it moves freely, the problem was the throttle/transmission arm. If the control handle is still hard to operate, disconnect the cable from the control. If the lever operates smoothly, the control cable needs replacement. If the lever is still hard to move, lubricate the lever pivot point in the control with penetrating oil and a light grease.
- c. If the problem is with a throttle lever, you may have a cable brake installed to limit cable feedback to the handle. If this is the case, loosen or remove the brake. If throttle lever creep back is a problem on the boat, you should consider installing a Teleflex CH5600 SLT control. This unit will stop cable creep without sacrificing a smooth feel.

How Does the CH5600 Work?

Each control lever has both a self-locking and direct drive lever arm. The cable from the engine throttle directly to the control should be connected to the control's self-locking lever arm. The cable from the transmission should only be connected to the control's direct-drive lever arm. Cables between stations should only be connected to the direct drive lever arms of those controls.

CH5600 SLT-two types of lever arms:

Direct Drive Lever Arm:

When a cable from the transmission or a "slave station" is connected to the direct-drive arm, it will allow the control lever to be moved from another station. Cables from the main station to any additional stations must be attached to direct drive arms on those stations.

Self-Locking Lever Arm:

When a cable from the throttle is connected to the self-locking arm (black in color), it will only move if the lever is moved; engine vibration and return spring feedback will not move the control lever. Only throttle cables routed directly from the engine to the control should be connected to self-locking lever arms.

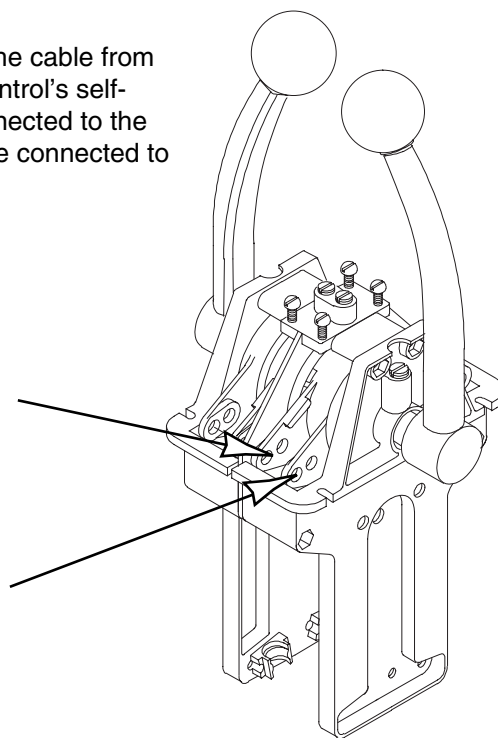

Inside the CH5600:

This exploded view diagram shows key components and features of the SLT top mount control. The SLT can be configured as throttle/shift, throttle/throttle, or shift/shift.

This control is designed to work well with virtually any 3300/33C type universal cable. For *superior* results, use Teleflex TFXTREME® cables.

For a list of part numbers for available options and replacement items, see the CH5600 pages earlier in this section.

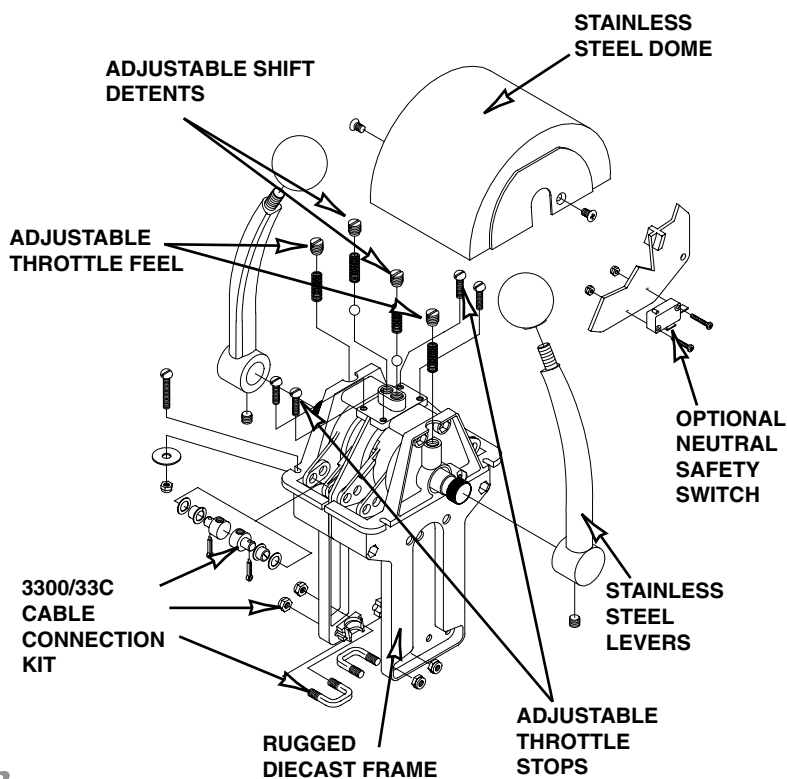

How Do I Set-up the CH5600?

Throttle/Shift Configuration:

Each SLT can be configured for Throttle and Shift, Twin Throttle or Twin Shift, simply by screwing in the appropriate throttle stops, detents and knobs that come with the control. **Shift cables must always be connected to the direct drive arm**, regardless of which control station.

Single & Dual Station Use:

The SLT can be used in Single or Twin Station applications. Dual station setups must only utilize the Self-Locking feature, shift detents and throttle stops **for throttle at the station whose cables are directly connected to the engine**. All cables from the “master” control to the other station(s) must be connected to the direct drive arms of secondary control(s), which must not have active throttle friction or shift detents. **Multiple stations require that the controls be hooked in series if the Self-Locking feature is used.**

NOTE: The SLT feature should only be used for throttle. (Gear shift cable needs free movement at the lever to properly engage the transmission detent.) The SLT feature should only be used on the station-to-engine (“master”) control. (Cables running from control to control must be able to move freely at all times.)

NOTE: This is the only twin station mechanical control that allows you to take full advantage of TFXTREME® cables’ superior performance characteristics. You can use the ultra-smooth TFXTREME cables without requiring a cable brake or other device to limit unwanted lever creep. Cable brakes and similar devices tend to denigrate cable performance and degrade the feel of the control when the levers are moved.

SINGLE STATION:

THROTTLE CONTROL CABLE END ATTACHED TO SELF-LOCKING CONTROL ARM (CABLE FEEDBACK STOPPED HERE) — SHIFT CABLE END ATTACHED TO DIRECT-DRIVE ARM.

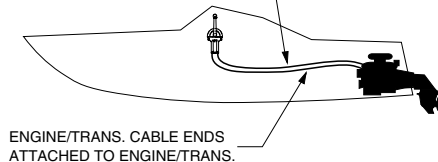

DUAL STATION:

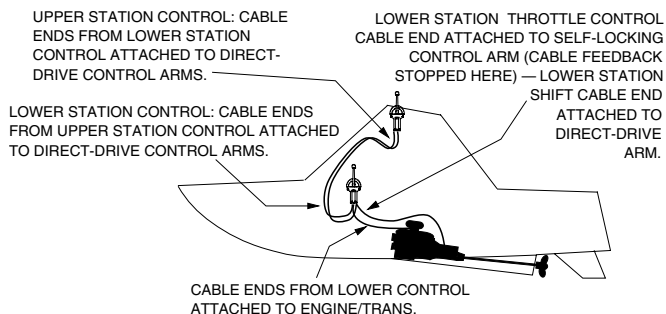

Tech Reference: Controls

Frequently Asked Questions (continued)

How do I know which control cable I need?

In order to determine that, you need to know what brand(s) of engine and control head are on the boat. Mercury/Mariner/Force and OMC/Johnson/Evinrude engines usually require an "OEM type" cable when using those engine makers' control heads. OEM type cables have special end fittings designed to connect to the control and engine with minimal hardware. Generally, all other engines and controls use a "universal" 3300/33C type control cable. Universal cables have 10-32 threaded ends and often require extra hardware to connect to the engine and control. Contact the engine manufacturer if you need details on the hookup. Diesels and twin station vessels may use larger diameter (4300/43 or 6400/64 type) universal cables; 4300/43 type cables have 1/4-28 threaded ends and 6400/64 cables have 5/16-24 threaded ends. Refer to the "Control Cables" section of this catalog for more information.

How do I know which control cable length I need?

This depends on two things:

a. Are you doing a first-time control cable installation?

Outboards: Measure from control along unobstructed cable routing to center of outboard. Add two feet to allow for loop which provides unrestricted engine movement. Round up to next whole foot and order that length cable(s).

Stern Drives and Inboards: Measure from control along unobstructed cable routing to shift and/or throttle connection. Round this dimension off to the next whole foot and order that length cable(s).

b. Are you replacing an existing cable?

Measure the Existing Cable as Follows: Measure the cable from tip to tip in inches, and round up to next even foot. Order that length cable.

What kind of ongoing maintenance do cables need? Can they be repaired?

We suggest the following periodic maintenance be performed at least twice a season:

- a. Check overall operation for proper gear engagement, full and idle throttle, and overall feel.
- b. Visually inspect control head, cable as well as engine and transmission cable attachment points for proper tightness of fasteners, correct operation of all moving parts, worn or broken items, cable chafing or misalignment, etc.
- c. Do not lubricate core wire (moving wire inside the casing). If the cable operates stiffly, replace it.
- d. Keep cable ends dirt and corrosion free.
- e. Lubricate pivot points and sliding parts of the cable with a good quality water-resistant grease.

When to replace a cable or connection hardware:

- a. Excessive free play felt at the control even after all cable connections have been verified as in good working order.
- b. Visual inspection shows chafing, breakage or bent, loose or worn parts.

Never attempt to repair a cable. Always replace a malfunctioning cable. A cable cannot be properly repaired in the field and must always be replaced as an assembly. Attempting to repair a cable can result in control system failure, leading to personal injury and/or property damage.

How to Measure Control Cables

"Measure Twice. Order Once."

For a New Installation:

Measure cable routing path from control head attachment point to engine connection, as follows:

Outboards:

Measure from control along unobstructed cable routing to center of outboard. Add four feet to allow for loop which provides unrestricted engine movement. Round up to next whole foot and order required cable part number. (Last two digits of cable part number equal cable length in feet.)

TYPICAL OUTBOARD CABLE ROUTING:

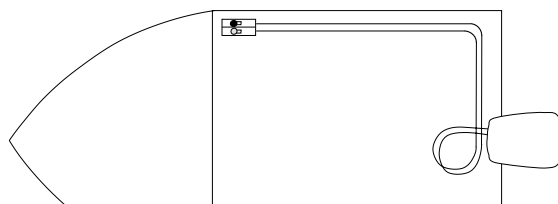

TYPICAL OUTBOARD CABLE ROUTING
(MEASURE CABLE PATH + ROUND UP TO NEXT EVEN FOOT + ADD 4 FEET FOR LOOP AT ENGINE TO PREVENT KINKING)

TYPICAL STERN DRIVE (I/O) OR INBOARD CABLE ROUTING:

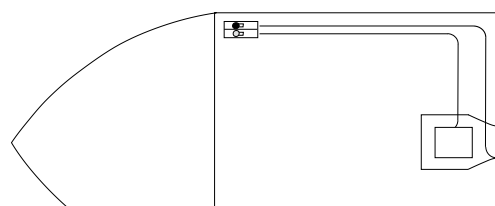

TYPICAL STERN DRIVE/INBOARD CONTROL CABLE ROUTING
(MEASURE CABLE PATH + ROUND UP TO NEXT EVEN FOOT)

Inboards & Stern Drives:

Measure from control along unobstructed cable routing to shift and/or throttle connection. Round this dimension off to the next whole foot and order required cable part number. (Last two digits of cable part number equal cable length in feet.)

For Replacement of Existing Cable:

If you removed the old cable, measure for replacement cable as follows:

Measure from tip to tip and round up to next whole foot, if necessary (aftermarket cables are sold in foot increments).

The control cable part number contains its length. Teleflex cables are usually listed as CC???XX, where XX = length in feet. Morse cables are listed as ??????-??-XXX.0, where XXX.0 = length in inches.

For example:

Part Number CC63320 = 20 ft. CC633 Control Cable
or
Part Number 032377-03-240.0 = 20 ft. 33C Control Cable
(240" = 20')

If you need further assistance, please contact Teleflex Marine Technical Service at 610-495-7011 visit us on-line at www.teleflexmarine.com.

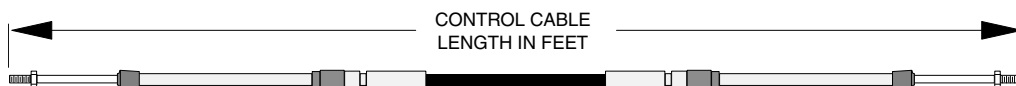

Tech Reference: Controls

Installation Tips (Engine Controls & Cables)

Control cable routing paths should be chosen to minimize bends, kinks and obstructions.

Cable routing with a few gradual bends will result in better feel at the control than one with many sharp bends.

- a. Avoid tight or sharp bends in the cable routing.
- b. Take care not to kink the jacket (casing) or core wire.
- c. Handle cable with care during installation/maintenance.
- d. Keep cable away from excessive heat and moisture. (Do not route near exhaust manifolds or in a bilge, for example.)
- e. Don't lubricate core wire (moving wire inside the casing).
- f. Make sure cable moves freely before connecting to control and engine. Keep cable ends aligned correctly.
- g. Keep cable ends dirt and corrosion free.
- h. Lubricate pivot points and sliding parts of the cable with a good quality water-resistant grease.

When connecting the THROTTLE control cable, ensure that cable travel and feel are properly adjusted:

- a. Adjust cable position so that throttle lever movement allows the full throttle range, from idle to full speed. This can be done at the engine end of OEM type cables and at either end of "universal" type cables.
- b. Adjust lever stops in control (if so equipped) to limit lever movement to slightly less than cable travel. This adjustment will help prevent cable damage if the lever is moved beyond the cable's range of travel.
- c. Adjust cable or lever brake (if so equipped) so that lever is easy to move, but does not creep due to vibration.
- d. In twin station applications, do not engage cable or lever brake at upper station control. This will create additional drag and make the control difficult to operate.

- e. In all cases, ensure that the cable end is aligned properly with the control lever arm (control end) and throttle arm (engine end). A control cable must swivel somewhat throughout its range of movement; ensure that the cable anchor points can swivel freely throughout its range of movement.

When connecting the SHIFT control cable, ensure that cable travel and feel are properly adjusted:

- a. Adjust cable position so that shift lever movement allows the full shift range, from neutral to forward and reverse, with full engagement of forward and neutral. Ensure that control detents (if so equipped) are synchronized with transmission detents, so that lever action matches the appropriate shift arm movement at the transmission. This can be done at the engine end of OEM type cables and at either end of "universal" type cables.
- b. Adjust lever stops in control (if so equipped) to limit lever movement to slightly less than cable travel. This adjustment will help prevent cable damage if the lever is moved beyond the cable's range of travel.
- c. Don't use a cable brake or lever brake on the shift cable. The cable must have some free movement to allow the transmission's shift detents to "center" themselves.
- d. In twin station applications, do not engage the control's detents at upper station control. This will make it difficult to properly engage forward, neutral and reverse.
- e. In all cases, ensure that the cable end is aligned properly with the control lever arm (control end) and shift arm (engine end). A control cable must swivel somewhat throughout its range of movement; ensure that the cable anchor points can swivel freely throughout its range of movement.

Many documents can be downloaded as Acrobat® PDF files from our web site: www.teleflexmarine.com

Shift and Throttle Control Cables

The control cable is a very important component in the control system. It is the vital link between the control head and the propulsion unit. Employing the best cable helps insure that your shift and throttle system operates smoothly and efficiently. The design, technology, and materials which are used in Teleflex Marine cables have literally set the standard for the entire marine industry.

Our control cables are environmentally tested for marine applications. They have stainless steel terminals and conduit fittings as well as stainless or

nylon covered core wires with moisture protective seals for added corrosion protection and longer life. Their durable HDPE outer jackets resist abrasion and withstand the effects of UV, salt water, chemicals, gasoline, and oil. Each Teleflex Marine cable is lifetime lubricated at the factory.

Teleflex Marine pioneered the development of high efficiency control cables. Since not all cables utilize this technology there can be significant operating differences between Teleflex Marine cables and other brands.

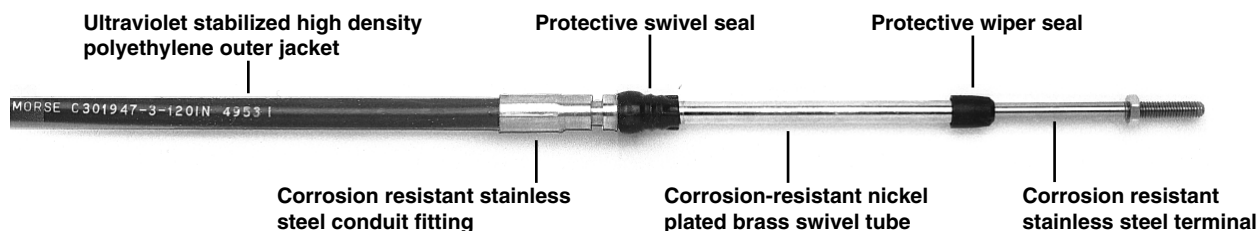

33 Supreme cable shown; some cables use non-plated brass fittings and swivel/guide tubes. All exposed areas are made from corrosion-resistant materials.

How to Choose the Right 3300/33C Cable:

Teleflex Marine offers several models of universal 3300/33C type cables, each suited to certain operating conditions and installation parameters. Below are key variables that affect how cables perform:

Backlash: the lost motion between the amount of movement put in (input end of the cable) and the amount of movement which occurs at the output end of the cable. Some motion is generally lost in “take up” between the inner wire (core) of the cable and the outer casing (conduit). Backlash manifests itself as free play (slop) felt at the control handle.

Efficiency: the percentage of input force that is transmitted through the cable as output force. For example, if a 10-pound force was exerted on the cable at its input end and resulted in the cable exerting an 8-pound output force, the cable would be 80% efficient.

Breakaway: the “feel” of the cable when put into motion; the breakaway threshold is the force that must be applied to the cable’s input end before something happens at the output end. An example of excessive breakaway: a control that would have to be moved to half-throttle before the engine responded.

Cable Routing: the shorter and straighter the cable routing, the better the cable will perform. With increased length and bends, cable efficiency is reduced, while breakaway and backlash rise.

Environment: generally, the more rugged the cable construction, the longer the cable will last. In harsh environments such as heavy salt and UV exposure, control cables with thicker conduits and stainless steel fittings will generally outlast those with thinner conduits and brass or steel fittings.

Cable design, manufacturing tolerances, length and installation care are additional factors to consider.

3300/33C CABLE TYPE	BACK-LASH	BREAK-AWAY/ EFFICIENCY	LONG/ COMPLEX ROUTINGS	HARSH ENVIRONMENT
CC172	Good	Good	Good	Good
33C	Better	Better	Better	Superior
33 Supreme	Very Good	Very Good	Very Good	Superior
CC633	Superior	Superior	Superior	Superior

For definitions of terms used in this chart, see the accompanying article.

Tech Reference: Controls

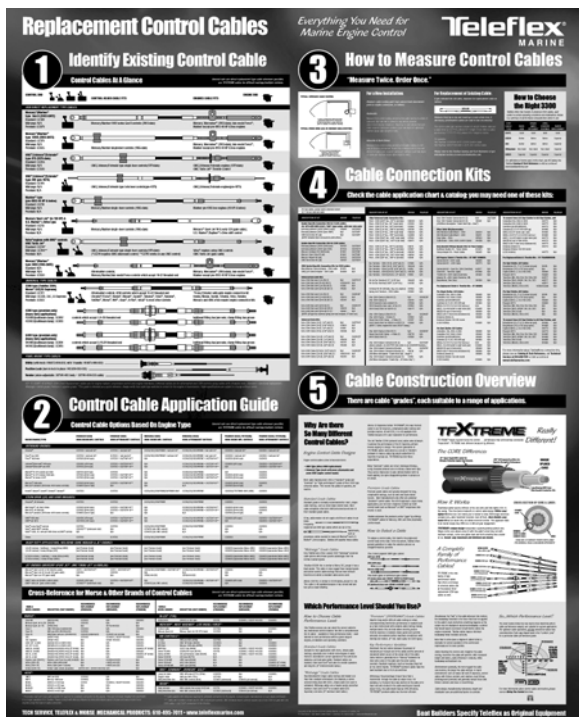

If you're selling Teleflex Marine steering and controls, you'll like these posters.

Packed with useful information, they'll help you identify steering systems, control cables and replacement options at a glance!

Want one?

Contact Teleflex Marine Marketing Services at 217-324-9430 or on-line at www.teleflexmarine.com

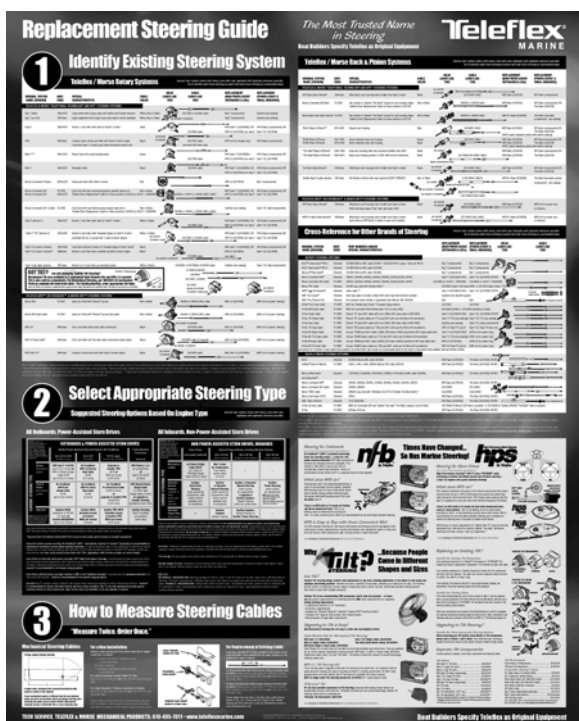

Many documents can be downloaded as Acrobat® PDF files from our web site: www.teleflexmarine.com